

Acoustic Design Guide

 **martini**

Contents

The CSR Martini Approach to Acoustics	2
Tried and Tested	3
Substitution can Affect Performance	3
Why is Fibre Important?	4
Sustainability	5
CSR Martini Acoustic Solutions	6
Acoustic Product Selector	6
Introduction to Building Acoustics	7
How is Sound Measured?	8
How Performance is Measured	9
Flow Resistivity	9
How Sound Travels in Buildings	10
Flanking Noise	10
Transmission	11
Sound Absorption	12
CSR Martini Acoustic Product Range	14
CSR Martini Acoustic Systems	18
Multi-residential Applications	19
Residential Applications	22
Commercial Applications	24

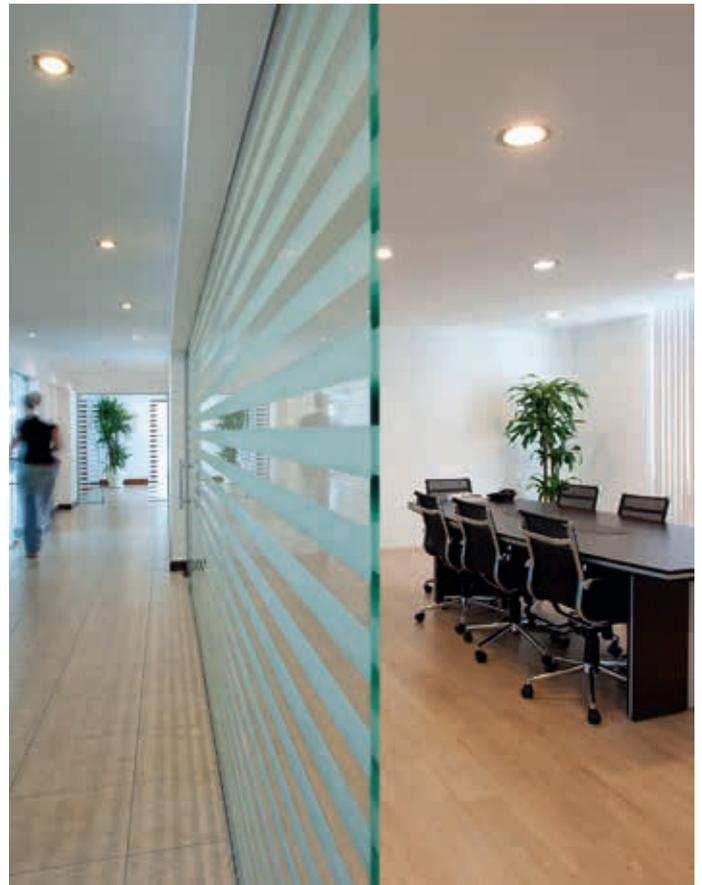

The CSR Martini Approach to Acoustics

CSR Martini has built a strong reputation in the development and manufacture of high quality, high performance products that create comfortable, liveable environments.

With emphasis on noise control in buildings, our products are specifically engineered to deliver maximum acoustic performance.

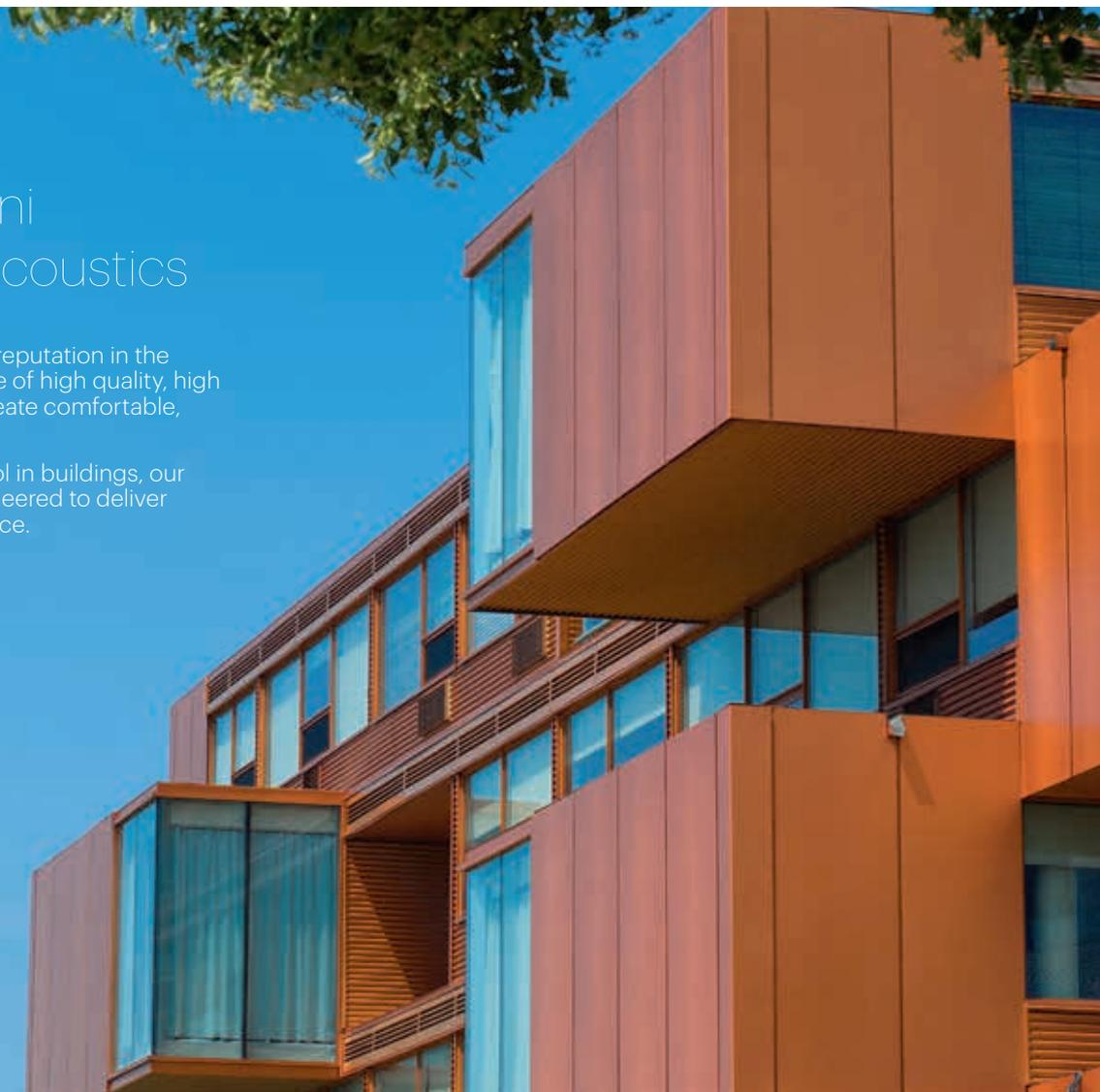

Tried and Tested

Investment in extensive acoustic testing offers you the assurance that comes with actual results rather than just opinions. Our products deliver exceptional performance, and we have the results to prove it.

Our products have excelled in some of the most challenging acoustic applications including recording studios, concert halls, auditoriums and theatres.

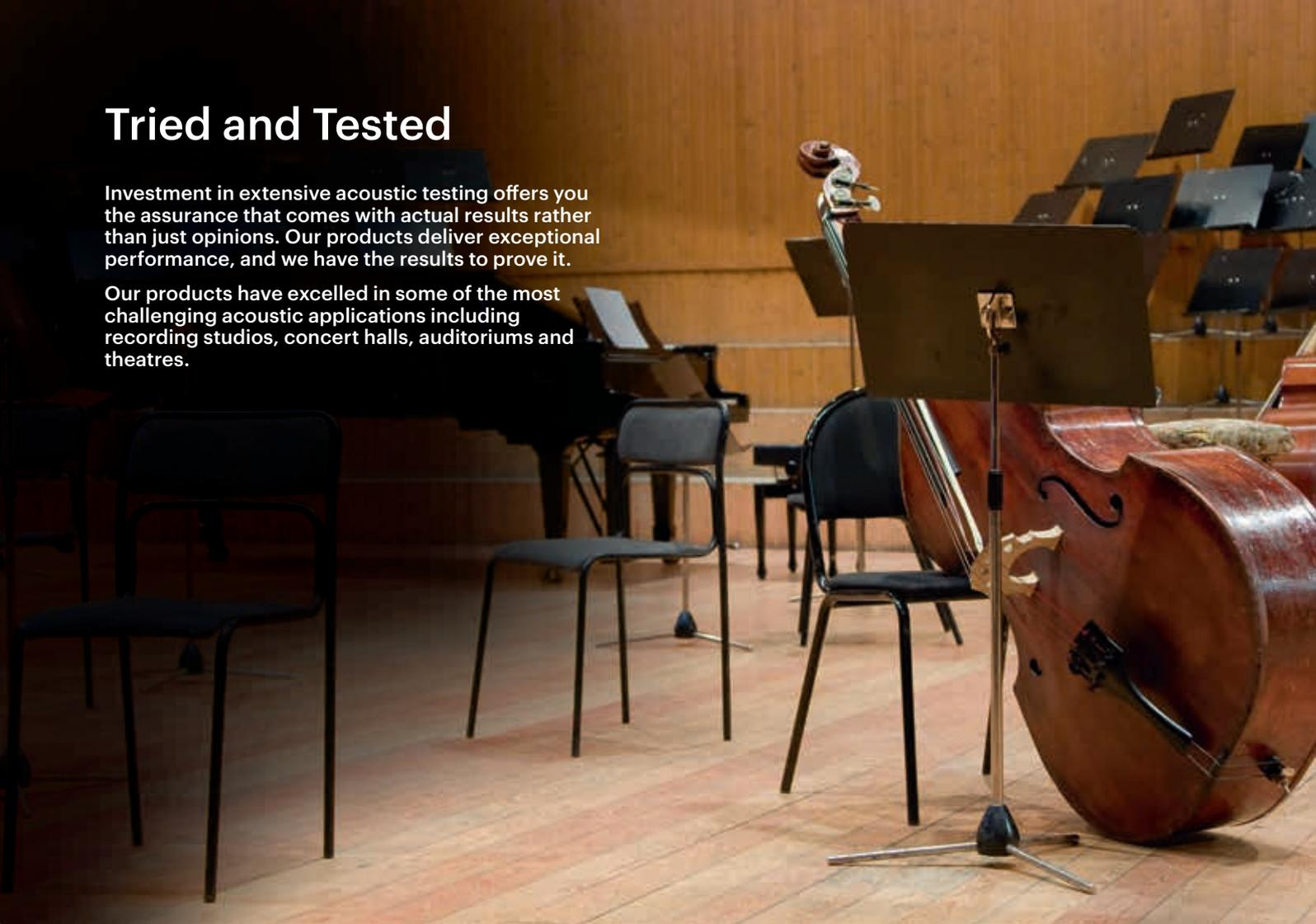

Substitution can Affect Performance

CSR Martini's products are engineered to perform, therefore the substitution of materials for specified products detailed in this guide may affect performance. Acoustic properties vary due to product thickness, density and fibre characteristics and the risk of substitution often outweighs any benefit.



Why is Fibre Important?

Fibre diameter is significant for acoustic insulation products. Air trapped between fibres reacts with sound energy and is converted to heat. The more fibres per square metre of insulation, the greater the surface area for absorption, which translates into superior acoustic performance.

Two insulation products of the same density and thickness can vary significantly in their acoustic performance due to a difference in fibre characteristics.

CSR Martini acoustic insulation products are manufactured with a specific blend of very fine low denier fibres. Other products may utilise coarser (larger denier) fibre blends which will have an adverse effect on acoustic performance.

Fine fibres substantially enhance acoustic absorption. If the average fibre diameter is halved (as per the diagram), the surface area for heat and sound energy to be absorbed and dissipated increases significantly.

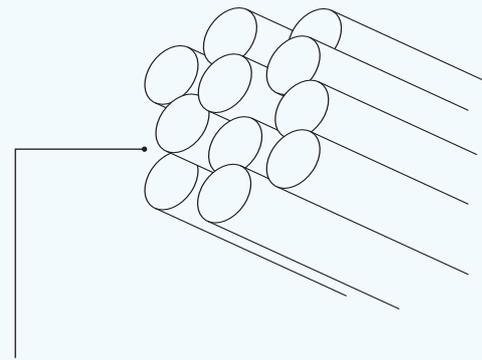

Coarse fibre diameter

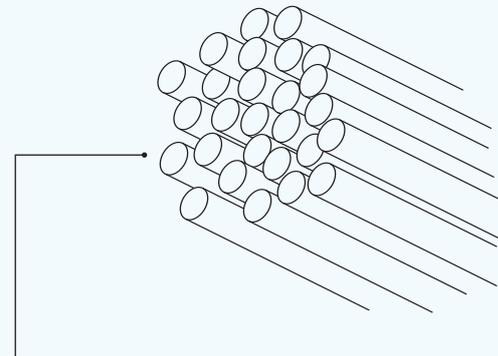

Fine fibre example provides twice the surface area for sound absorption





Sustainability

CSR Martini is focused on producing environmentally neutral and recyclable products through sustainable manufacturing processes.

As a result, our products:

- Contain up to 80% recycled material from post-consumer packaging
- Are manufactured without added chemicals or binders
- Are manufactured without water
- Are free of Volatile Organic Compounds (VOC)
- Use no ozone-depleting gases in manufacture

Green Tag

Independent environmental assessments have been completed by Ecospecifier on Martini's range of products and are ideal for use in Green Star® projects.

Recognised by the Green Building Council of Australia (GBCA) and Green Building Council of New Zealand (NZGBC), CSR Martini products can contribute to points available in the rating tools that assess the environmental sustainability of building projects at the design, construction and as built phases: Green Star® – Design & As Built, and the interior fit-out phase: Green Star® – Interiors.

Our dECO Series is GreenTag certified GreenRate Level 1 – the highest level achievable.



CSR Martini Acoustic Solutions

CSR Martini offers a wide range of products for all areas of your project, from wall and ceiling insulation for reducing noise transfer between areas, to decorative absorptive panels to help reduce reverberation and improve the acoustic comfort of a space.



Acoustic Product Selector

Acoustic Application	Martini MSB	Martini MAB	Martini Easy Baffle	Martini Absorb	Martini Prime	dECO Series
Multi-residential Walls & Ceilings	✓	✓	—	✓	✓✓	—
Commercial Wall & Ceilings	✓✓	✓✓	✓	✓✓	✓	—
Ceiling Voids	—	—	✓✓	—	—	—
Specialised Sound Absorption Projects	—	✓	—	✓✓	—	—
Decorative Interiors	—	—	—	—	—	✓✓

✓✓ Recommended

✓ Suitable for certain applications

— Not recommended

Introduction to Building Acoustics

Acoustics is an extremely important consideration in the design of any building. Spaces with poor acoustics will have a negative impact on the enjoyment and wellbeing of their occupants.

This CSR Martini Acoustic Design Guide details the various CSR Martini products used to control sound. It does not provide definitive solutions for every potential noise problem. Acoustics is a complex science, and we recommend the services of a specialist Acoustic Consultant be engaged where appropriate for the type of project or system being designed.





How is Sound Measured?

In order to create acoustically comfortable spaces, typically Acoustic Engineers analyse the frequency ranges of noise sources in and around the space to ensure the acoustic insulation solution recommended is suited to the sources of noise.

By understanding the frequencies of sound within a space, the correct acoustic insulation can be specified to create acoustically comfortable environments for the occupants.

Humans can hear frequencies from 20 to 20,000 Hz. The following table provides a guide to typical frequency ranges of selected noise sources.

20 – 15,000 Hz	Hi-fi music
30 – 4,000 Hz	Piano
50 – 100 Hz	Heavy vehicle engine noise
100 – 300 Hz	Light vehicle engine noise
200 – 1,600 Hz	Human speech
300 – 1,000 Hz	Air traffic noise
500 – 1,000 Hz	Phone ringing
800 – 2,000 Hz	Roadside (tyre) noise
1,000 – 4,000 Hz	Whistling
2,000 – 8,000 Hz	Birds chirping

How Performance is Measured

Noise Reduction Coefficient (NRC)

The performance of sound absorptive insulation is typically described by the Noise Reduction Coefficient (NRC) of the product. The NRC is a simplified single number that is the arithmetic average of four frequencies: 250 Hz, 500 Hz, 1,000 Hz and 2,000 Hz.

In sound absorption applications, the NRC is often used as a performance measure. The higher the NRC, the greater the sound absorption at those frequencies.

However, NRC does not rate sound absorption at frequencies less than 250 Hz. Absorption at the low frequency is often the most critical in building acoustics, as it is typically these bass sounds that cause annoyance. Therefore absorptive insulation products should also be rated by their performance at lower frequencies.



Flow Resistivity

Acoustic Engineers also measure the acoustic performance of products used in sound absorption applications by their resistance to air flow, known as **flow resistivity**. This performance measurement is helpful when comparing products of the same density and thickness that have differing fibre characteristics.

The table below rates the flow resistivity of Martini Absorb products measured in Rayl_{MKS}.

Product	RAYL _{MKS}
Absorb HD	7,994
Absorb XHD	14,693
Absorb XXHD	20,008

How Sound Travels in Buildings

Noise that travels through the air from one space can transmit through walls and ceilings and follow flanking paths through doors, stairwells and service voids above suspended ceilings. Noise can also reverberate and echo within a space, bouncing off hard surfaces such as polished floors and walls. The following is an overview of the way noise travels in building spaces.

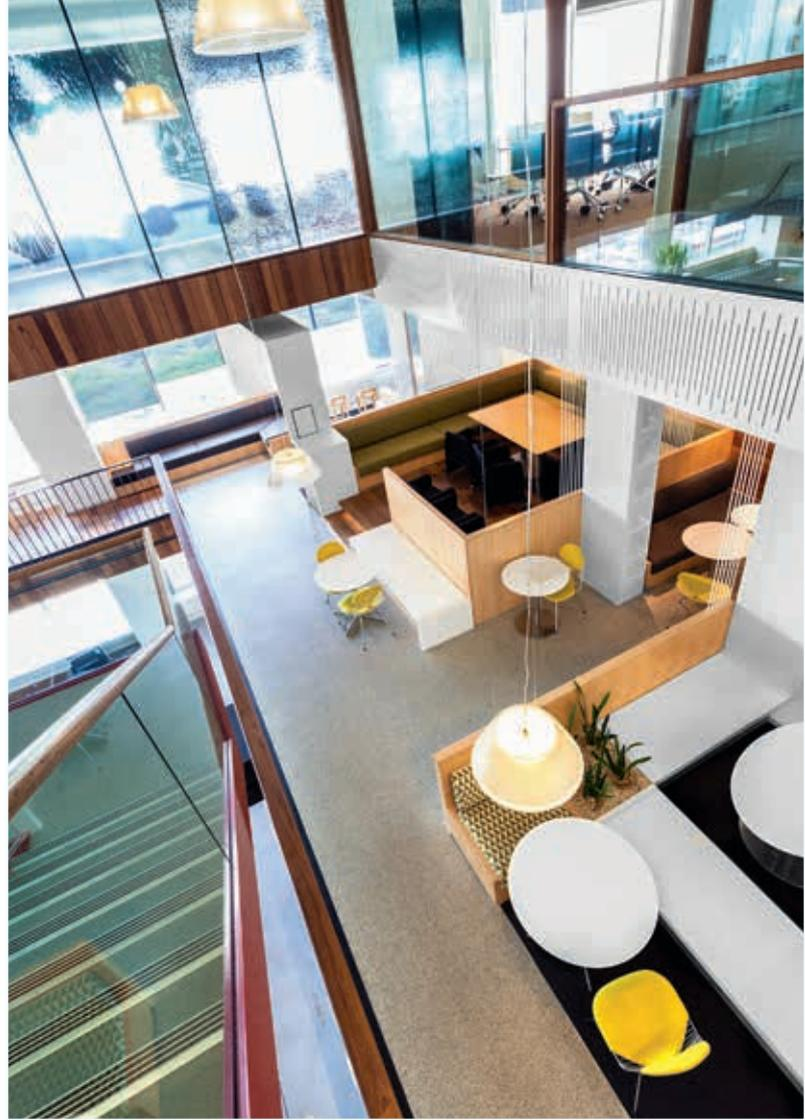

Flanking Noise

Consider an office that is adjacent to a meeting room, with a partition wall and suspended ceiling construction. Noise between these two rooms can be heard, as the service void space above the suspended ceiling provides a pathway for flanking nuisance noise to travel from one space to an adjoining room.

Flanking can also occur via doors and corridors as well as stairwells. Even though the wall system has been designed to high acoustic standards, the design can be compromised by flanking paths, specifically with plasterboard wall systems that do not continue above the suspended ceiling to the soffit.

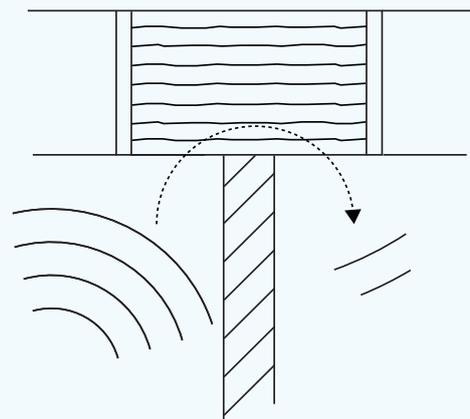

Product Solutions:



Transmission

Transmission refers to noise that is transferred between adjoining spaces through the walls and ceilings. This is particularly of concern in residential units, hotels, aged care and offices, where activities in one space can disrupt peaceful enjoyment of a neighbouring unit or area.

Building elements such as plasterboard ceilings and walls are normally laboratory tested to establish their sound insulation performance as a system rather than testing the individual building materials.

A laboratory test generally involves the installation of a specimen between two rooms, isolated from each other to prevent flanking noise interference so that only direct transmission can take place.

A steady known sound level of various frequencies is generated on one side of the specimen and then measured on the other side. Sound transmission loss through the specimen can be calculated for each frequency. The higher the transmission loss, the better the sound insulation performance of the building element.

There are two main measurements of the performance of a wall or ceiling system in reducing sound transmission:

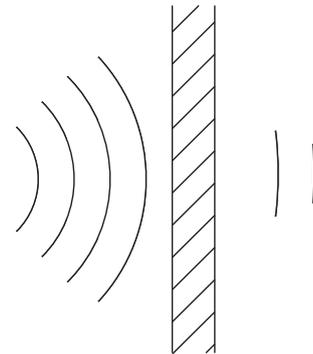

R_w

Sound transmission loss performance of walls and floors is described as R_w , which stands for weighted sound reduction index. An increase of one R_w point is equivalent to a one-decibel reduction in noise transmission through the element. Walls in commercial buildings are required to have a minimum R_w performance.

Product Solutions:



$R_w + C_{tr}$

In some applications, the R_w does not account for all noises, especially low frequency bass noises generated from home theatre and hi-fi systems. The C_{tr} value is used to modify the measured sound insulation performance. Smaller negative C_{tr} values are more favourable than large negative values.

The higher the $R_w + C_{tr}$ value of the wall system, the more effective it will be at reducing low frequency sound transmission. $R_w + C_{tr}$ performance is influenced by the material properties of the element including weight, thickness, stiffness and type of insulation used in the cavity. Common walls and ceilings used in multi-residential buildings require a minimum performance of $R_w + C_{tr}$ 50.

Sound Absorption

In buildings, sound waves can also be reflected internally by the surface of a space, causing reverberation. In spaces with predominately hard and acoustically reflective surfaces, reverberation can become uncomfortable, as sound is not absorbed before the sound wave decays.

In any space where people gather, such as offices, restaurants, sporting venues and theatres, good acoustic design is important to minimise this type of reverberant noise.

Poor acoustic design can lead to poor concentration levels, leading to loss of productivity, patronage and profits. An extended period of exposure to uncontrolled reverberation in a space has shown adverse effects to health and wellbeing.

Sound absorptive insulation offers a solution to the reverberation and echo of noises in a space. The most effective means of control is to use insulation materials with high levels of sound absorption appropriate to the frequency of the sound. For these materials to be effective they must be open to the sound source and are usually either included in perforated wall and ceiling systems or decorative panels attached to the interior surface of the space.

Sound absorptive materials differs and do not absorb all sound frequencies equally. Sound absorption is influenced by factors such as material density, thickness and, in the case of polyester insulation products, fibre size and diameter.

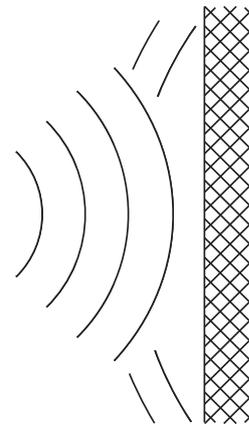

Product Solutions:



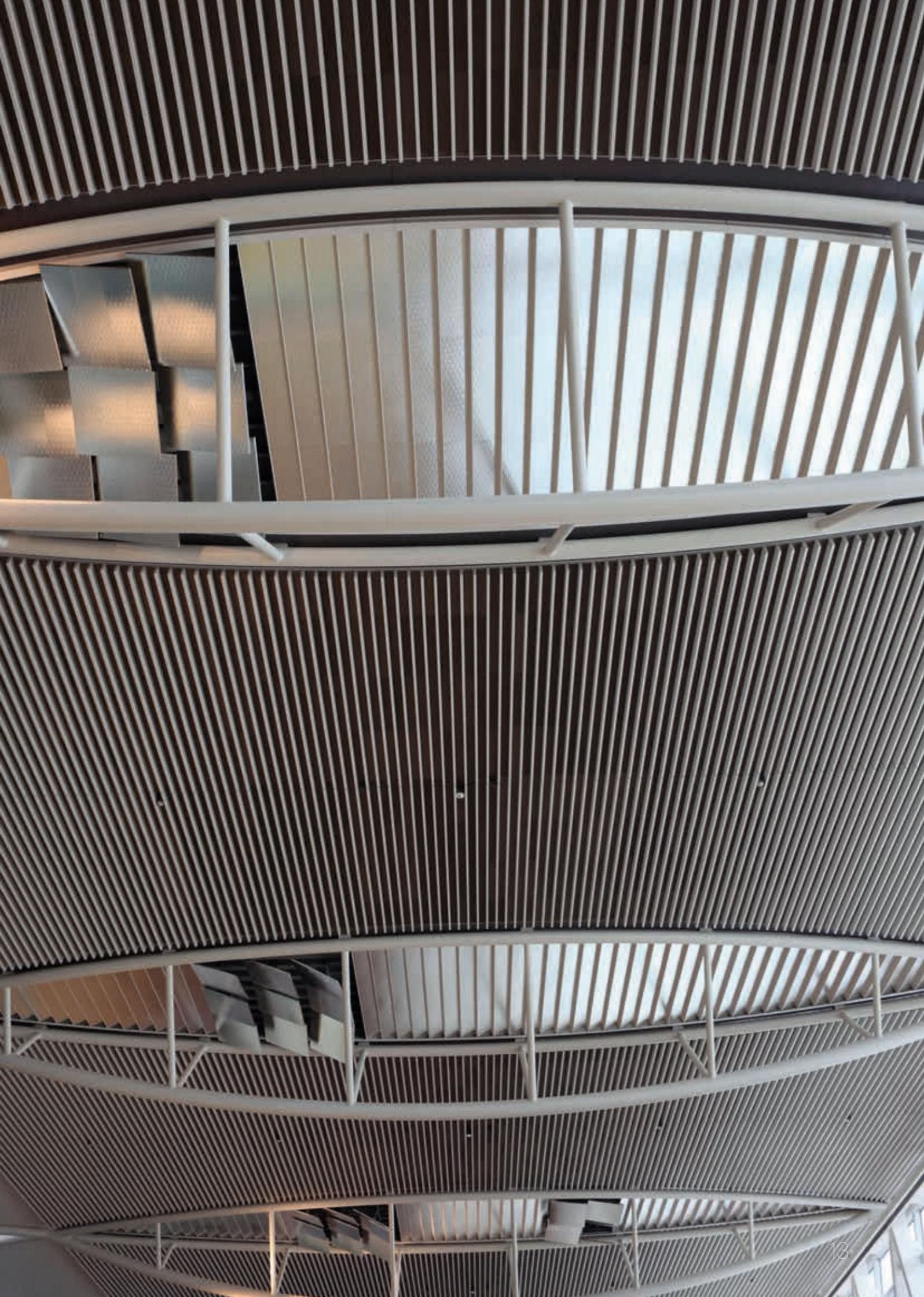

CSR Martini Acoustic Product Range

We have specifically engineered a range of acoustic insulation products that provide acoustic performance solution for a wide range of applications and building types. These include:



MSB is designed for use in plasterboard partition walls and suspended ceilings in commercial and community buildings. Installed in partition walls, Martini MSB provides sound transmission reduction and thermal performance, reducing heat and sound transfer between rooms.



An effective, easy-to-install barrier to reduce flanking noise that can travel between rooms through ceiling voids above suspended ceilings in office and commercial buildings.



Recommended for a range of commercial and industrial applications where acoustic performance is required. Offering both sound transmission reduction and absorption, Martini MAB is manufactured in a range of densities from 11kg/m³ to 60kg/m³ and thickness ranging from 25mm to 100mm.

Martini MAB is recommended for use as a cavity infill where noise separation through walls and ceilings is required, behind perforated panelling and ceiling to reduce echo, and in spaces such as sport halls, cinemas, studios, HVAC ducts, silencers and plant rooms.

Decorative Acoustic Range



A range of high performance sound absorptive panels and interior surface linings that deliver maximum design flexibility and superior acoustic performance at speech range frequencies.

The dECO Series boards, panels and screens provide design freedom with an extensive range of colours and fabric finishes and can be customised to suit any interior.

To find out more, visit www.csrmartini.com.au



High Performance Range

Martini Absorb and Martini Prime provide superior acoustic performance.



Martini Absorb is specifically designed to provide high performance sound absorption across a broad range of frequencies. It is highly effective at reducing echo in rooms and provides even sound absorption across the speech range frequencies and lower bass frequencies.

It is ideal for use in areas such as:

- behind perforated panelling and ceilings in sports halls, auditoriums, cinemas, studios, industrial enclosures, HVAC ducts, silencers or plant rooms.
- cavity infill where low frequency noise separation through walls and ceilings is required.
- above suspended ceilings to reduce flanking noise between rooms.

Martini Absorb is available in a range of densities and thicknesses with fibres specifically engineered to provide maximum thermal and acoustic performance in many diverse commercial, residential, community and industrial applications.



Designed for use in high performance plasterboard, masonry and aerated concrete composite walls and ceilings in multi-residential apartments, sole occupancy units (SOU) and other developments where low frequency sound transmission control is required.

The tables and graphs following show the sound absorption of various Martini Absorb products at various frequencies.

Absorb MD 25

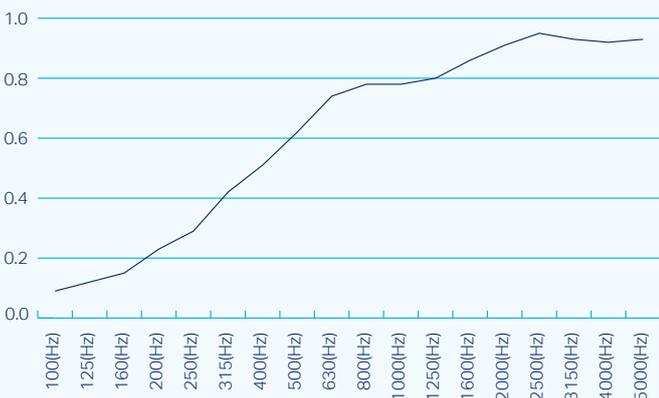

Absorb MD 25	
Frequency (Hz)	Sound Absorption Coefficients (αs)
100	0.09
125	0.12
160	0.15
200	0.23
250	0.29
315	0.42
400	0.51
500	0.62
630	0.74
800	0.78
1000	0.78
1250	0.80
1600	0.86
2000	0.91
2500	0.95
3150	0.93
4000	0.92
5000	0.93
aw	0.60 (H)
NRC	0.65

Absorb MD 50



Absorb MD 50	
Frequency (Hz)	Sound Absorption Coefficients (αs)
100	0.14
125	0.24
160	0.30
200	0.40
250	0.54
315	0.66
400	0.75
500	0.90
630	0.94
800	0.99
1000	0.98
1250	0.95
1600	0.97
2000	1.01
2500	1.02
3150	1.05
4000	1.06
5000	1.09
aw	0.85
NRC	0.85

Absorb HD 50



Absorb HD 50	
Frequency (Hz)	Sound Absorption Coefficients (αs)
100	0.12
125	0.22
160	0.27
200	0.42
250	0.54
315	0.79
400	0.91
500	1.02
630	1.03
800	1.05
1000	1.07
1250	1.06
1600	1.08
2000	1.04
2500	1.10
3150	1.07
4000	1.11
5000	1.14
aw	0.90
NRC	0.95

Absorb HD 75



Absorb HD 75	
Frequency (Hz)	Sound Absorption Coefficients (αs)
100	0.27
125	0.41
160	0.49
200	0.64
250	0.85
315	1.04
400	1.02
500	1.15
630	1.19
800	1.12
1000	1.11
1250	1.08
1600	1.06
2000	1.07
2500	1.11
3150	1.13
4000	1.16
5000	1.18
aw	1.00
NRC	1.05

Absorb HD 100



Absorb HD 100	
Frequency (Hz)	Sound Absorption Coefficients (αs)
100	0.46
125	0.54
160	0.69
200	0.94
250	1.12
315	1.08
400	1.16
500	1.13
630	1.04
800	1.01
1000	0.97
1250	0.98
1600	0.93
2000	0.94
2500	0.96
3150	0.97
4000	0.99
5000	0.99
αw	1.00
NRC	1.00

Absorb XHD 50

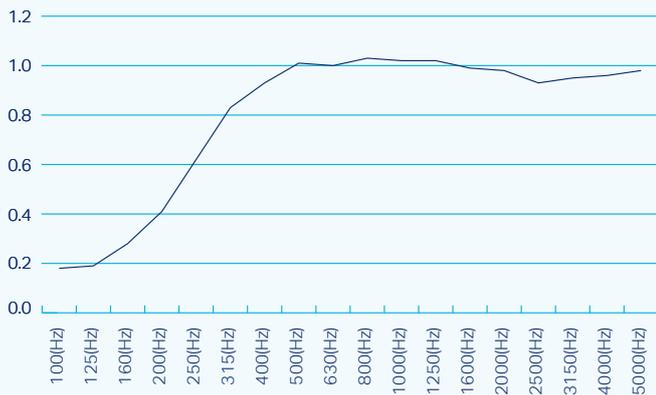

Absorb XHD 50	
Frequency (Hz)	Sound Absorption Coefficients (αs)
100	0.18
125	0.19
160	0.28
200	0.41
250	0.62
315	0.83
400	0.93
500	1.01
630	1.00
800	1.03
1000	1.02
1250	1.02
1600	0.99
2000	0.98
2500	0.93
3150	0.95
4000	0.96
5000	0.98
αw	0.90
NRC	0.90

Absorb XHD 100



Absorb XHD 100	
Frequency (Hz)	Sound Absorption Coefficients (αs)
100	0.55
125	0.55
160	0.76
200	1.12
250	1.18
315	1.23
400	1.17
500	1.15
630	1.12
800	1.01
1000	0.99
1250	1.00
1600	0.97
2000	1.00
2500	0.99
3150	0.99
4000	1.01
5000	0.98
αw	1.00
NRC	1.00

CSR Martini Acoustic Systems

Multi-residential Applications

National Construction Code (NCC) Provisions

The National Construction Code (NCC) mandates certain minimum acoustic requirements for building elements in apartment projects. The following is an extract from the NCC.

$R_w + C_{tr} \geq 50$

Default rating for walls and floors between SOUs (Sole Occupancy Units). In some cases the partition may also need to be of discontinuous construction. For floors, there may also be a minimum sound impact ($L_n, w + C_I$) rating requirement.*

$R_w \geq 50$

Walls between a SOU and a plant room or lift (discontinuous construction) or public corridor, public lobby, stairway or similar.

$R_w + C_{tr} \geq 40$

Walls or floors separating a duct, soil, waste or water supply pipe or stormwater pipe (Class 2 and 3 Buildings).

Walls or floors separating a duct, soil, waste or water supply pipe or stormwater pipe from a habitable room (Class 1 Buildings).



Multi-residential Applications

MA20280

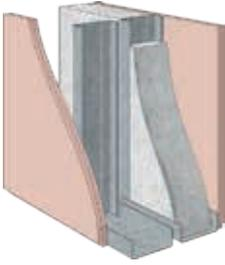

Product Specification

Martini R2.0 Acoustic Batts

Side 1 Linings:

2 layers of 16mm Gyprock Fyrchek™

Side 2 Linings:

2 layers of 16mm Gyprock Fyrchek™

Frame Arrangement:

Separated Studs. Two rows of studs with a minimum 20mm separation. Insulation, when specified, to one stud frame only.

Stud Material:

Steel

Stud Size:

64 x 0.50/0.55mm Gauge

Stud Spacing:

600 mm

Cavity Width:

148 mm

Wall Width:

212 mm

R_w

60

$R_w + C_{tr}$

53

MA25131



Product Specification

Martini R2.5 Acoustic Batts

Side 1 Linings:

1 layer of 13mm Gyprock Soundchek®

Side 2 Linings:

1 layer of 13mm Gyprock Soundchek®

Frame Arrangement:

Staggered Studs. Studs located in track or angle with minimum 20mm clearance to lining on one side.

Stud Material:

Steel

Stud Size:

92 x 0.50/0.55mm Gauge

Stud Spacing:

600 mm

Cavity Width:

150 mm

Wall Width:

176 mm

R_w

57

$R_w + C_{tr}$

50

MA25132

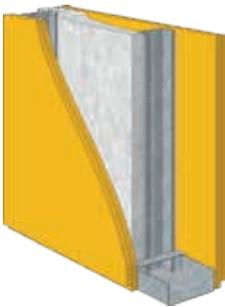

Product Specification

Martini R2.5 Acoustic Batts

Side 1 Linings:

2 layers of 13mm Gyprock Soundchek®

Side 2 Linings:

2 layers of 13mm Gyprock Soundchek®

Frame Arrangement:

Staggered Studs. Studs located in track or angle with minimum 20mm clearance to lining on one side.

Stud Material:

Steel

Stud Size:

92 x 0.50/0.55mm Gauge

Stud Spacing:

600 mm

Cavity Width:

150 mm

Wall Width:

202 mm

R_w

63

$R_w + C_{tr}$

56

MA25153

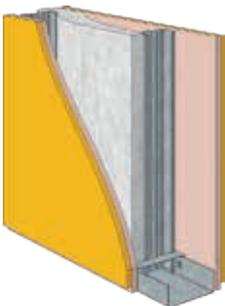

Product Specification

Martini R2.5 Acoustic Batts

Side 1 Linings:

1 layer of 16mm Gyprock Fyrchek™
1 layer of 13mm Gyprock Soundchek®

Side 2 Linings:

1 layer of 16mm Gyprock Fyrchek™
1 layer of 13mm Gyprock Soundchek®

Frame Arrangement:

Staggered Studs. Studs located in track or angle with minimum 20mm clearance to lining on one side.

Stud Material:

Steel

Stud Size:

92 x 0.50/0.55mm Gauge

Stud Spacing:

600 mm

Cavity Width:

150 mm

Wall Width:

208 mm

R_w

64

$R_w + C_{tr}$

57

*Sound impact requirements are not covered in this acoustic design guide.

Multi-residential Applications

MA25175

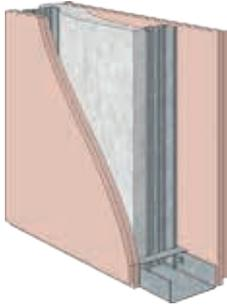

Product Specification

Martini R2.5 Acoustic Batts

Side 1 Linings:

1 layer 16 mm Gyprock Fyrchek™
1 layer of 13mm Gyprock Fyrchek™

Side 2 Linings:

1 layer 16 mm Gyprock Fyrchek™ MR
1 layer of 13mm Gyprock Fyrchek™

Frame Arrangement:

Staggered Studs. Studs located in track or angle with minimum 20mm clearance to lining on one side.

Stud Material:	Steel
Stud Size:	92 x 0.50/0.55mm Gauge
Stud Spacing:	600 mm
Cavity Width:	150 mm
Wall Width:	208 mm
R_w	63
R_w + C_{tr}	56

MA25207

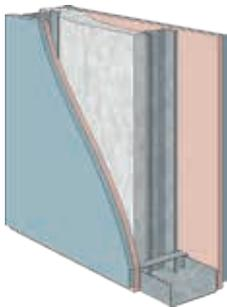

Product Specification

Martini R2.5 Acoustic Batts

Side 1 Linings:

1 layer of 13mm Gyprock Fyrchek™
1 layer of 6mm Ceminseal Wallboard

Side 2 Linings:

1 layer of 13mm Gyprock Fyrchek™
1 layer of 6mm Ceminseal Wallboard

Frame Arrangement:

Separated Studs. Two rows of studs with a minimum 20mm separation. Insulation, when specified, to one stud frame only.

Stud Material:	Steel
Stud Size:	92 x 0.50/0.55mm Gauge
Stud Spacing:	600 mm
Cavity Width:	150 mm
Wall Width:	188 mm
R_w	62
R_w + C_{tr}	55

MA50153

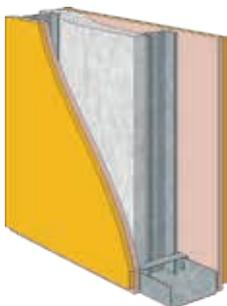

Product Specification

Martini Prime 50

Side 1 Linings:

1 layer of 16mm Gyprock Fyrchek™
1 layer of 13mm Gyprock Soundchek®

Side 2 Linings:

1 layer of 16mm Gyprock Fyrchek™ MR
1 layer of 13mm Gyprock Soundchek®

Frame Arrangement:

Staggered Studs. Studs located in track or angle with minimum 20mm clearance to lining on one side.

Stud Material:	Steel
Stud Size:	92 x 0.50/0.55mm Gauge
Stud Spacing:	600 mm
Cavity Width:	150 mm
Wall Width:	208 mm
R_w	57
R_w + C_{tr}	50

MA75175

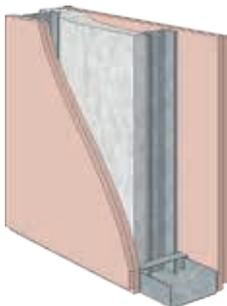

Product Specification

Martini Prime 75

Side 1 Linings:

1 layer of 16mm Gyprock Fyrchek™
1 layer of 13mm Gyprock Fyrchek™

Side 2 Linings:

1 layer of 16mm Gyprock Fyrchek™ MR
1 layer of 13mm Gyprock Fyrchek™

Frame Arrangement:

Staggered Studs. Studs located in track or angle with minimum 20mm clearance to lining on one side.

Stud Material:	Steel
Stud Size:	92 x 0.50/0.55mm Gauge
Stud Spacing:	600 mm
Cavity Width:	150 mm
Wall Width:	208 mm
R_w	59
R_w + C_{tr}	52

MA75207

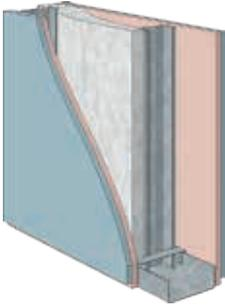

Product Specification

Martini Prime 75

Side 1 Linings:

1 layer of 13mm Gyprock Fyrchek™
1 layer of 6mm Cemirseal Wallboard

Side 2 Linings:

1 layer of 13mm Gyprock Fyrchek™
1 layer of 6mm Cemirseal Wallboard

Frame Arrangement:

Staggered Studs. Studs located in track or angle with minimum 20mm clearance to lining on one side.

Stud Material:	Steel
Stud Size:	92 x 0.50/0.55mm Gauge
Stud Spacing:	600 mm
Cavity Width:	150 mm
Wall Width:	188 mm
R_w	58
R_w + C_{tr}	51

MA75275

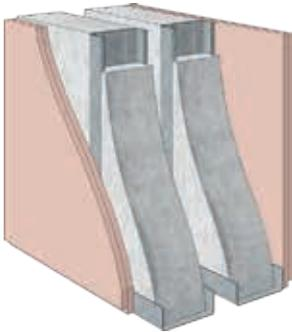

Product Specification

Martini Prime 75

Note: Insulation is required in both stud rows

Side 1 Linings:

2 layers of 13mm Gyprock Fyrchek™

Side 2 Linings:

2 layers of 13mm Gyprock Fyrchek™

Frame Arrangement:

Separated Studs. Two rows of studs with a minimum 20mm separation. Insulation to both stud frames.

Stud Material:	Steel
Stud Size:	51 x 0.50/0.55mm Gauge
Stud Spacing:	600 mm
Cavity Width:	122 mm
Wall Width:	174 mm
R_w	60
R_w + C_{tr}	52

MA75280

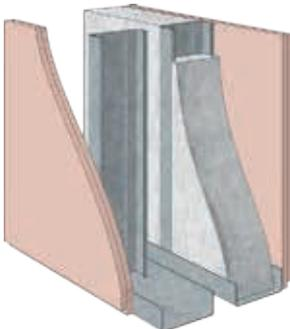

Product Specification

Martini Prime 75

Note: Insulation is required in one stud row only

Side 1 Linings:

2 layers of 16mm Gyprock Fyrchek™

Side 2 Linings:

2 layers of 16mm Gyprock Fyrchek™

Frame Arrangement:

Separated Studs. Two rows of studs with a minimum 20mm separation. Insulation, when specified, to one stud frame only.

Stud Material:	Steel
Stud Size:	64 x 0.50/0.55mm Gauge
Stud Spacing:	600 mm
Cavity Width:	148 mm
Wall Width:	212 mm
R_w	57
R_w + C_{tr}	50

Residential Applications

MA20326

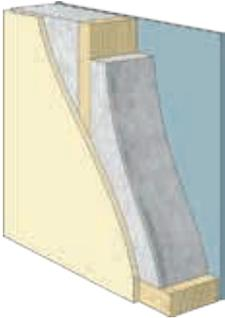

Product Specification
Martini R2.5 Acoustic Batts

Side 1 Linings:
1 layer of 13mm Gyprock™
Standard Plasterboard

Side 2 Linings:
1 layer of 9mm Ceminseal Wallboard

Frame Arrangement:
Single Studs

Stud Material:	Timber
Stud Size:	90 x 35mm Width
Stud Spacing:	450 mm
Cavity Width:	90 mm
Wall Width:	112 mm
R_w	42
R_w + C_{tr}	35

MA20354



Product Specification
Martini R2.0 Acoustic Batts

Side 1 Linings:
1 layer of 13mm Gyprock Soundchek®

Side 2 Linings:
1 layer of 13mm Gyprock Soundchek®

Frame Arrangement:
Single Studs

Stud Material:	Timber
Stud Size:	90 x 35mm Width
Stud Spacing:	450 mm
Cavity Width:	90 mm
Wall Width:	116 mm
R_w	42
R_w + C_{tr}	35

MA20475

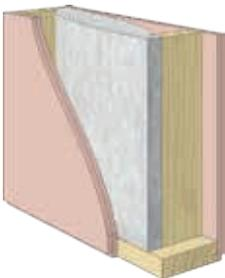

Product Specification
Martini R2.0 Acoustic Batts

Side 1 Linings:
2 layers of 13mm Gyprock Fyrchek™

Side 2 Linings:
2 layers of 13mm Gyprock Fyrchek™

Frame Arrangement:
Staggered Studs. Studs located in track or angle with minimum 20mm clearance to lining on one side.

Stud Material:	Timber
Stud Size:	90 x 35mm Width
Stud Spacing:	450 mm
Cavity Width:	120 mm
Wall Width:	172 mm
R_w	58
R_w + C_{tr}	52

MA20670

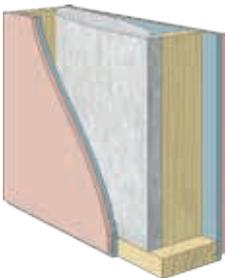

Product Specification
Martini R2.0 Acoustic Batts

Side 1 Linings:
1 layer of 6mm Ceminseal Wallboard
1 layer of 13mm Gyprock Fyrchek™

Side 2 Linings:
1 layer of 6mm Ceminseal Wallboard
1 layer of 13mm Gyprock Fyrchek™

Frame Arrangement:
Staggered Studs. Studs located in track or angle with minimum 20mm clearance to lining on one side.

Stud Material:	Timber
Stud Size:	90 x 35mm Width
Stud Spacing:	450 mm
Cavity Width:	120 mm
Wall Width:	158 mm
R_w	58
R_w + C_{tr}	52

MA25305

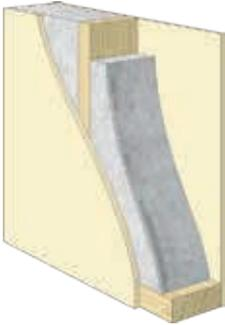

Product Specification
Martini R2.5 Acoustic Batts

Side 1 Linings:
1 layer of 10mm Gyprock™
Standard Plasterboard

Side 2 Linings:
1 layer of 10mm Gyprock™
Standard Plasterboard

Frame Arrangement:
Single Studs

Stud Material:	Timber
Stud Size:	90 x 35mm Width
Stud Spacing:	450 mm
Cavity Width:	90 mm
Wall Width:	110 mm
R_w	37
R_w + C_{tr}	30

MA25310



Product Specification
Martini R2.5 Acoustic Batts

Side 1 Linings:
1 layer of 13mm Gyprock™
Standard Plasterboard

Side 2 Linings:
1 layer of 13mm Gyprock™
Standard Plasterboard

Frame Arrangement:
Single Studs

Stud Material:	Timber
Stud Size:	90 x 35mm Width
Stud Spacing:	450 mm
Cavity Width:	90 mm
Wall Width:	116 mm
R_w	39
R_w + C_{tr}	32

MA25322

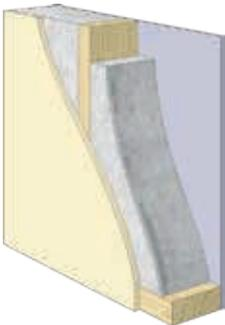

Product Specification
Martini R2.5 Acoustic Batts

Side 1 Linings:
1 layer of 13mm Gyprock™
Standard Plasterboard

Side 2 Linings:
1 layer of 13mm Gyprock Impactchek™

Frame Arrangement:
Single Studs

Stud Material:	Timber
Stud Size:	90 x 35mm Width
Stud Spacing:	450 mm
Cavity Width:	90 mm
Wall Width:	116 mm
R_w	40
R_w + C_{tr}	33

Commercial Applications

MA20044

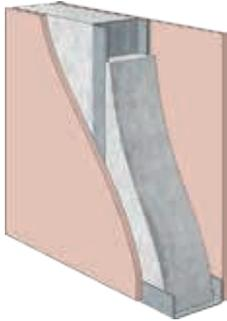

Product Specification

Martini R2.0 Acoustic Batts

Side 1 Linings:

1 layer of 13mm Gyprock Fyrchek™

Side 2 Linings:

1 layer of 13mm Gyprock Fyrchek™

Frame Arrangement:

Single Stud

Stud Material:

Steel

Stud Size:

92 x 0.50/0.55mm Gauge

Stud Spacing:

600 mm

Cavity Width:

92 mm

Wall Width:

118 mm

R_w

49

$R_w + C_{tr}$

42

MA25049

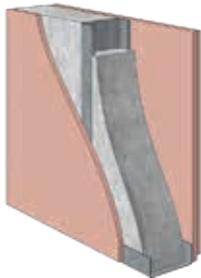

Product Specification

Martini R2.0 Acoustic Batts

Side 1 Linings:

1 layer of 16 mm Gyprock Fyrchek™

Side 2 Linings:

2 layers of 16mm Gyprock Fyrchek™

Frame Arrangement:

Single Stud

Stud Material:

Steel

Stud Size:

92 x 0.50/0.55mm Gauge

Stud Spacing:

600 mm

Cavity Width:

92 mm

Wall Width:

140 mm

R_w

53

$R_w + C_{tr}$

46

MA25110

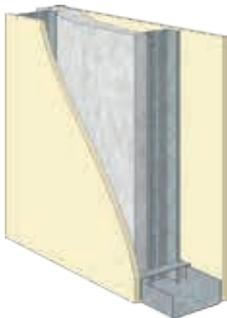

Product Specification

Martini R2.0 Acoustic Batts

Side 1 Linings:

1 layer of 13mm Gyprock™
Standard Plasterboard

Side 2 Linings:

1 layer of 13mm Gyprock™
Standard Plasterboard

Frame Arrangement:

Staggered Studs. Studs located in track or angle with minimum 20mm clearance to lining on one side.

Stud Material:

Steel

Stud Size:

92 x 0.50/0.55mm Gauge

Stud Spacing:

600 mm

Cavity Width:

150 mm

Wall Width:

176 mm

R_w

53

$R_w + C_{tr}$

45

MA65005

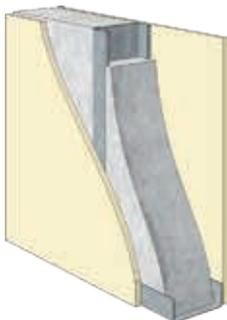

Product Specification

Martini Prime 65

Side 1 Linings:

1 layer of 10mm Gyprock™ Standard
Plasterboard

Side 2 Linings:

1 layer of 10mm Gyprock™ Standard
Plasterboard

Frame Arrangement:

Single Stud

Stud Material:

Steel

Stud Size:

64 x 0.50/0.55mm Gauge

Stud Spacing:

600 mm

Cavity Width:

64 mm

Wall Width:

84 mm

R_w

37

$R_w + C_{tr}$

29

MA65015

**Product Specification**

Martini Prime 65

Side 1 Linings:

2 layers of 13 mm Gyprock™
Standard Plasterboard

Side 2 Linings:

1 layer of 13 mm Gyprock™
Standard Plasterboard

Frame Arrangement:

Single Studs

Stud Material: Steel

Stud Size: 64 x 0.50/0.55mm Gauge

Stud Spacing: 600 mm

Cavity Width: 64 mm

Wall Width: 103 mm

R_w 44

R_w + C_{tr} 37

MA65032

**Product Specification**

Martini Prime 65

Side 1 Linings:

1 layer of 13mm Gyprock Soundchek®

Side 2 Linings:

1 layer of 13mm Gyprock Soundchek®

Frame Arrangement:

Single Studs

Stud Material: Steel

Stud Size: 64 x 0.50/0.55mm Gauge

Stud Spacing: 600 mm

Cavity Width: 64 mm

Wall Width: 90 mm

R_w 43

R_w + C_{tr} 36

MA65035

**Product Specification**

Martini Prime 75

Side 1 Linings:

2 layers of 10mm Gyprock Superchek™

Side 2 Linings:

2 layers of 10mm Gyprock Superchek™

Frame Arrangement:

Single Studs

Stud Material: Steel

Stud Size: 64 x 0.50/0.55mm Gauge

Stud Spacing: 600 mm

Cavity Width: 64 mm

Wall Width: 104 mm

R_w 52

R_w + C_{tr} 45

MA75040

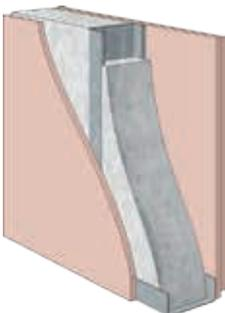
**Product Specification**

Martini Prime 75

Side 1 Linings:

1 layer of 13mm Gyprock Fyrchek™

Side 2 Linings:

2 layers of 13mm Gyprock Fyrchek™

Frame Arrangement:

Single Studs

Stud Material: Steel

Stud Size: 64 x 0.50/0.55mm Gauge

Stud Spacing: 600 mm

Cavity Width: 64 mm

Wall Width: 103 mm

R_w 50

R_w + C_{tr} 43

Commercial Applications

MA75050

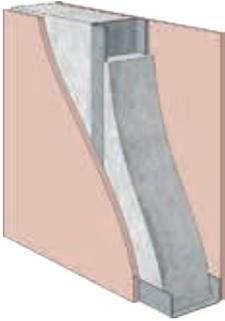

Product Specification

Martini Prime 75

Side 1 Linings:

1 layer of 13mm Gyprock Fyrchek™

Side 2 Linings:

1 layer of 13mm Gyprock Fyrchek™

Frame Arrangement:

Single Studs

Stud Material: Steel

Stud Size: 64 x 0.50/0.55mm Gauge

Stud Spacing: 600 mm

Cavity Width: 64 mm

Wall Width: 90 mm

R_w 46

R_w + C_{tr} 39

MA75605

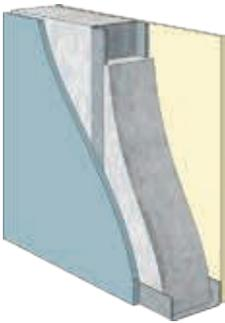

Product Specification

Martini Prime 75

Side 1 Linings:

1 layer of 6mm Ceminseal Wallboard™

Side 2 Linings:

1 layer of 13mm Gyprock™ Standard Plasterboard

Frame Arrangement:

Single Studs

Stud Material: Steel

Stud Size: 64 x 0.50/0.55mm Gauge

Stud Spacing: 600 mm

Cavity Width: 64 mm

Wall Width: 83 mm

R_w 43

R_w + C_{tr} 36

MA75606



Product Specification

Martini Prime 75

Side 1 Linings:

1 layer of 9mm Ceminseal Wallboard™

Side 2 Linings:

1 layer of 13mm Gyprock™ Standard Plasterboard

Frame Arrangement:

Single Studs

Stud Material: Steel

Stud Size: 64 x 0.50/0.55mm Gauge

Stud Spacing: 600 mm

Cavity Width: 64 mm

Wall Width: 86 mm

R_w 46

R_w + C_{tr} 39

The R_w, R_w + C_{tr} in this guide refer to expected results of a laboratory test on an element and are based on testing carried out by CSR Gyprock Fibre Cement. The performance values are provided by PKA Acoustic Consulting which use a prediction system based on these tests.

Bradford™ designSMART

TECHNICAL SERVICES

- Expert insulation advice
- Project and value engineering support
- Industry-leading building science research

A wealth of insulation experience and knowledge to build on

Bradford DesignSmart Technical Services delivers expert advice to help architects, engineers and builders create optimised insulation building solutions and specifications. **Call the DesignSmart team 1800 354 044**

Meet the DesignSmart technical team on [LinkedIn](#).



Joe Timi
Technical Service Manager



Liam Thai
Technical Sales Engineer



Jesse Clarke
Building Scientist



Malcolm McBlain
Technical Manager, Martini



Ed Hanley
Technical Sales Engineer



Mark Pohlner
Architectural Support

For more information visit BradfordDesignSmart.com.au

